



aerospace
climate control
electromechanical
filtration
fluid & gas handling
hydraulics
pneumatics
process control
sealing & shielding



Parker Sporlan Gas Cooler/ Flash Gas Bypass Valves

For Transcritical CO₂ (R-744) Applications



ENGINEERING YOUR SUCCESS.

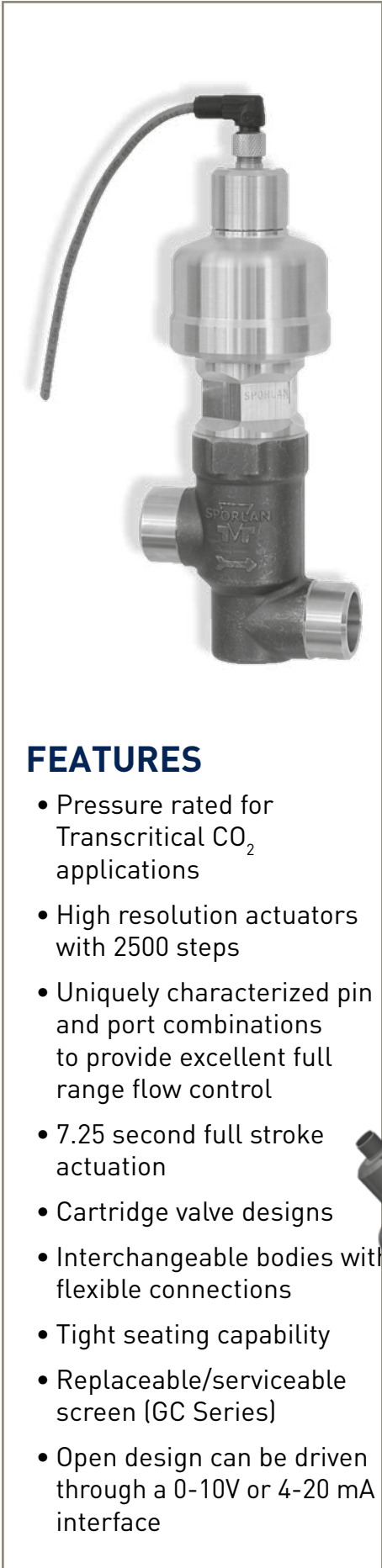

FEATURES

- Pressure rated for Transcritical CO₂ applications
- High resolution actuators with 2500 steps
- Uniquely characterized pin and port combinations to provide excellent full range flow control
- 7.25 second full stroke actuation
- Cartridge valve designs
- Interchangeable bodies with flexible connections
- Tight seating capability
- Replaceable/serviceable screen (GC Series)
- Open design can be driven through a 0-10V or 4-20 mA interface

GAS COOLER/FLASH GAS BYPASS VALVES

The Parker Sporlan GC and FGB valve families are stepper motor driven pressure regulating valves, designed specifically for transcritical R-744 refrigeration systems.

The GC -10, -20, -30, -40, and -50 are applicable as gas cooler / condenser holdback valves, but can also be applied as flash tank pressure regulating valves (flash gas bypass). The FGB -60 and -70 are specifically designed to extend the capacity range of the GC family when applied as flash gas bypass valves. All GC and FGB valves have 2500 steps of resolution, feature synthetic seat discs to ensure tight shutoff, and carry the same electronic controller requirements.

CONTROLS

The Parker Sporlan GC and FGB valves can be driven by utilizing the Parker Sporlan PSD4 Interface Board and PSS4B Backup Power Module. By providing either a 0-10VDC or 4-20 mA signal from a system controller, the PSD4 translates this signal in to a suitable stepper motor sequence to position the valve proportionally. Upon power loss, the PSS4B provides reserve power for one full valve closure, to isolate the refrigerant and minimize refrigerant loss due to venting.

VALVE CONSTRUCTION

The GC family features a cartridge construction, where the valve port is integrated into the stepper motor actuator assembly. Therefore, the valve family can be broken into two distinct pieces: the bodies and the cartridge assemblies.

The valve bodies are available with three connection sizes for butt or tube / socket welding: ½ inch (12.7 mm), ¾ inch (19.05 mm) and 1 inch (25.4 mm). The five cartridge assemblies contain the valve pin and port, and determine the ultimate valve capacity. The three bodies are compatible with all five cartridge assemblies, and can be paired in any combination to best fit the system piping and capacity requirements.

There is a screen located around the port inlet that is a part of the cartridge assembly, but can be removed for service if necessary.

The FGB family has a slightly different construction that minimizes pressure drop through the valve at full stroke. To achieve this result, the port is not integrated into the stepper motor actuator assembly, but is mounted directly into the valve body.

There is a single valve body available with a 1 inch (25.4 mm) connection for butt welding. Because this valve is installed in the low pressure side of the system, the option is also available to utilize an 1-1/8 inch (28.58 mm) ODF or 1-3/8 inch (34.93 mm) ODM braze joint.

There are two stepper motor actuator assemblies that contain the valve pin, and must be matched with the corresponding port. The port is threaded into the valve body, and is removable to service the port or to perform a capacity conversion.

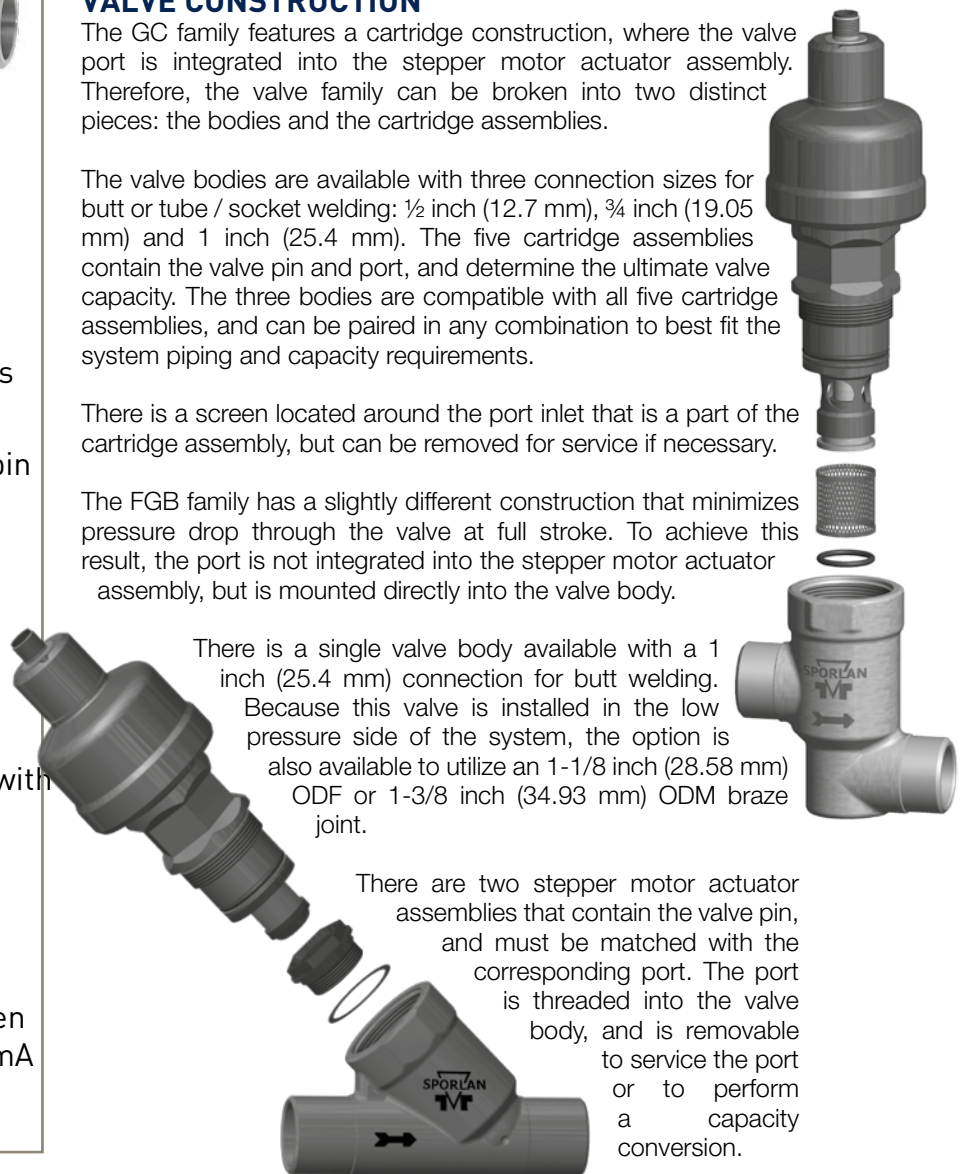

TYPICAL SYSTEM SCHEMATIC/THERMODYNAMIC CYCLE

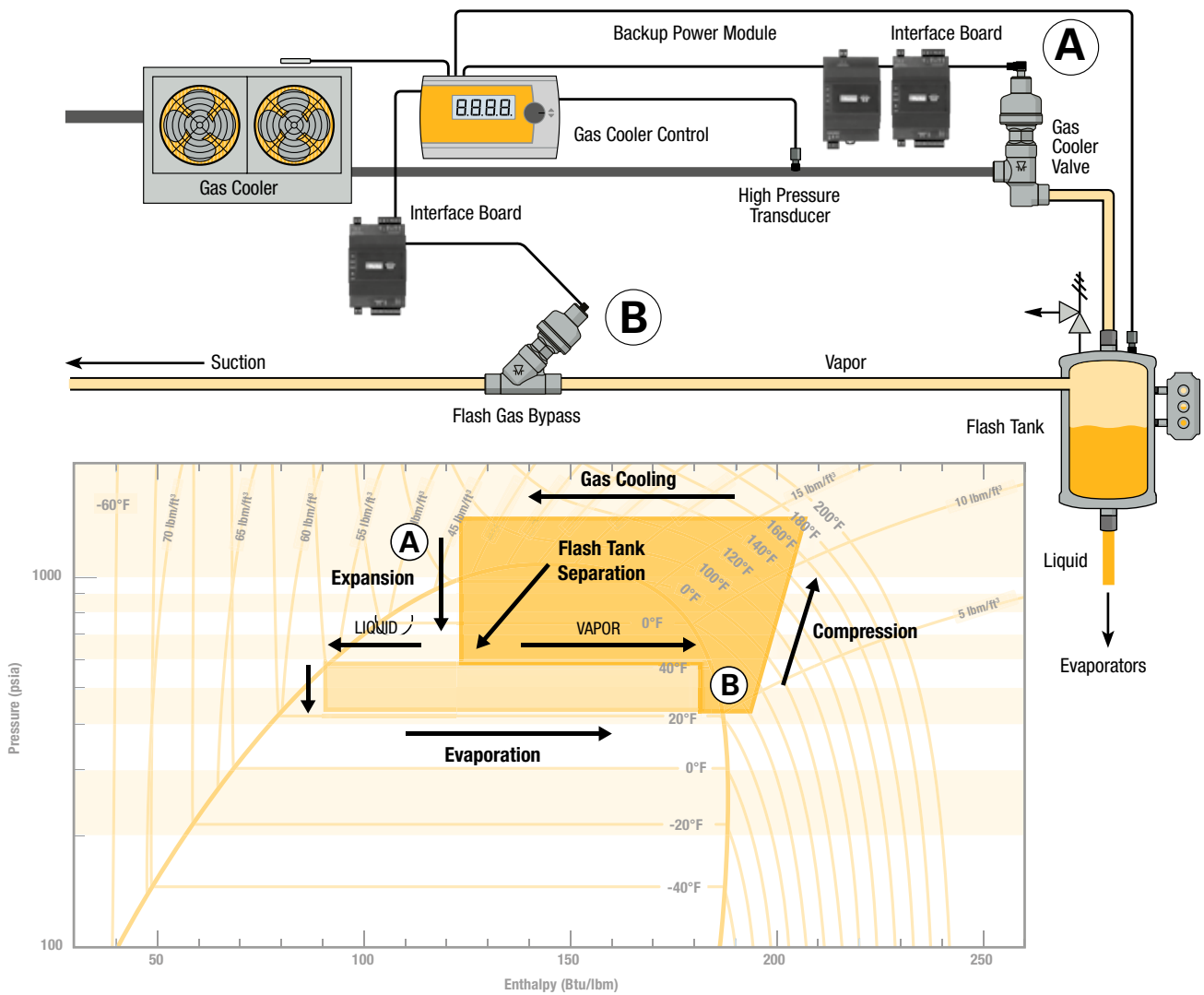

VALVE DRIVE SEQUENCE (IF DRIVEN DIRECTLY)

CABLE LEAD COLOR				
Step	Black	White	Red	Green
1	HI	0	HI	0
2	0	HI	HI	0
3	0	HI	0	HI
4	HI	0	0	HI
1	HI	0	HI	0

CLOSE ↓ ↑ OPEN

CABLE CONNECTION

Terminal Position	Lead Wire Color
1	Red
2	Green
3	White
4	Black

Cable is not orientation specific, and can be installed in any of four positions (90 degrees apart).

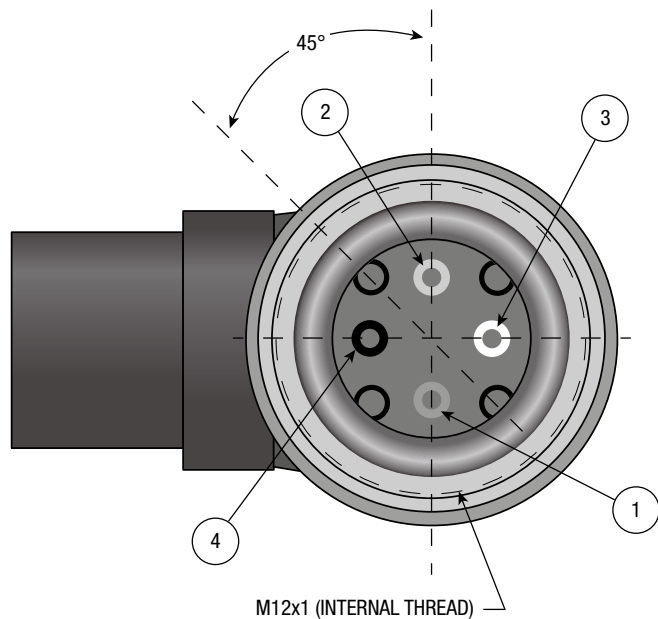

VALVE SPECIFICATIONS

Compatible Refrigerant	R-744
Motor Type	Permanent magnet bipolar internal (wet) motor
Phase Resistance	12.8 $\Omega \pm 10\%$
Phase Inductance	18.5 mH (Reference)
Phase Current	275 mA (using current limited / chopper drive)
Holding Current	0 mA
Step Mode	2 Phase, Full Step
Step Rate	400 PPS
Number of Steps	2500
Initialization Number of Steps	3125
Reference Position	Overdrive against fully closed position*
Full Stroke Transit Time	7.25 seconds
Internal Screen	259 micron (GC only)
Electrical Connection	M12 A-coded
MRP	140 barg (2030 psig)
MOPD	GC: 90 bar (1305 psid) FGB: 50 bar (725 psid)
Fluid Temperature Range	-40°C to 115°C (-40°F to 239°F)
Ambient Temperature Range	-40°C to 60°C (-40°F to 140°F)
Duty Cycle	50% at Maximum Fluid Temperature 100% at 100°C (212°F) or Lower Fluid Temperature
Max External Leakage	2.8 gm/yr @ 20 barg (.10 oz/yr at 300 psig)
Mounting Orientation	Motor Housing Vertical $\pm 45^\circ$
Materials of Construction	Stainless steel, brass, synthetic seals
Agency Certification	ULus (SA5460), CE, RoHS, REACH

*Overdriving open is permitted, but valve will drive open beyond 2500 steps.

GC FAMILY DIMENSIONS

CONNECTION SIZE	DIM 'A' - BUTT WELD	DIM 'B' - TUBE/SOCKET WELD
1/2" [12.7mm]	.84" [21.34mm]	.51" [12.95mm]
3/4" [19.05mm]	1.05" [26.67mm]	.76" [19.30mm]
1" [25.4mm]	1.315" [33.40mm]	1.01" [25.65mm]

FGB FAMILY DIMENSIONS

CONNECTION SIZE	DIM 'A' - BUTT WELD
1" [25.4mm]	1.315" [33.40mm]

DIM 'B' - ODM BRAZE	DIM 'C' - ODF BRAZE
1-3/8" [34.93mm]	1-1/8" [28.58mm]

VALVE DIMENSIONS (GC FAMILY)

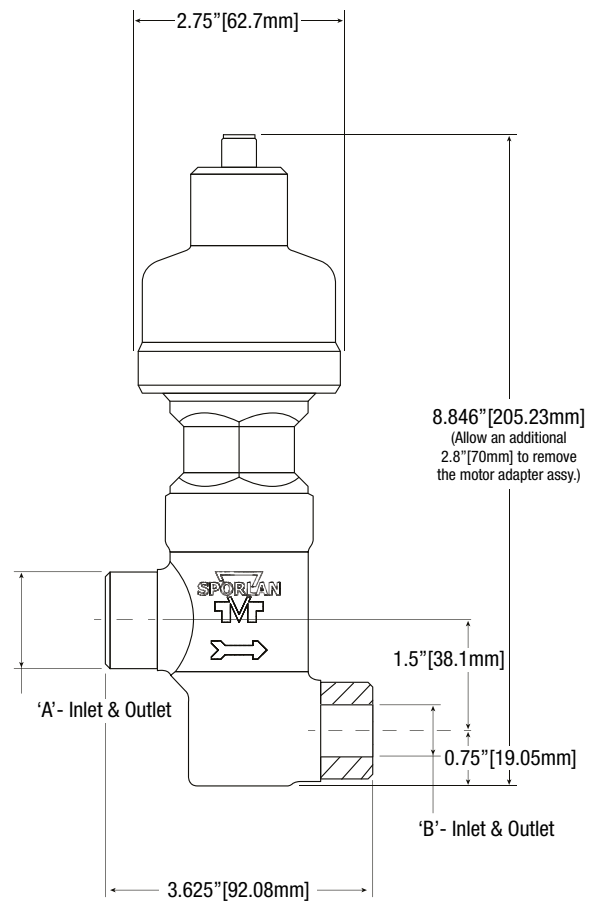

VALVE DIMENSIONS (FGB FAMILY)

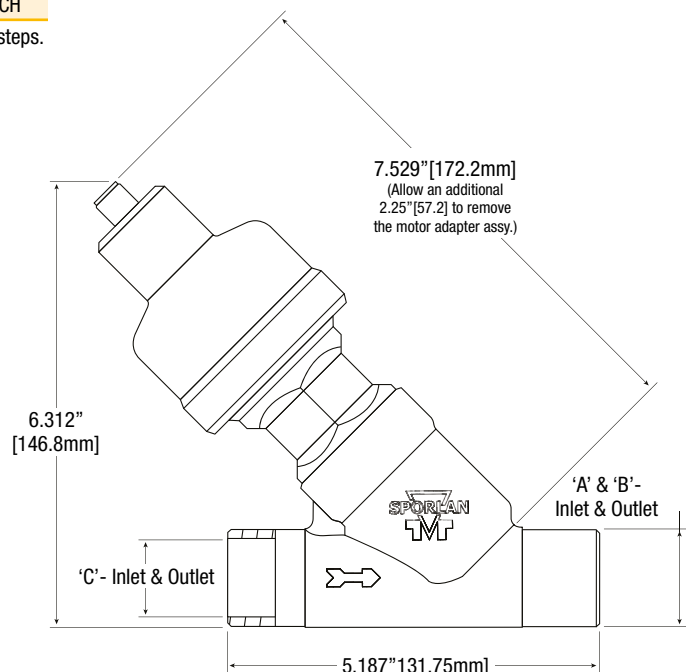

GAS COOLER VALVE CAPACITY FLOW CURVES

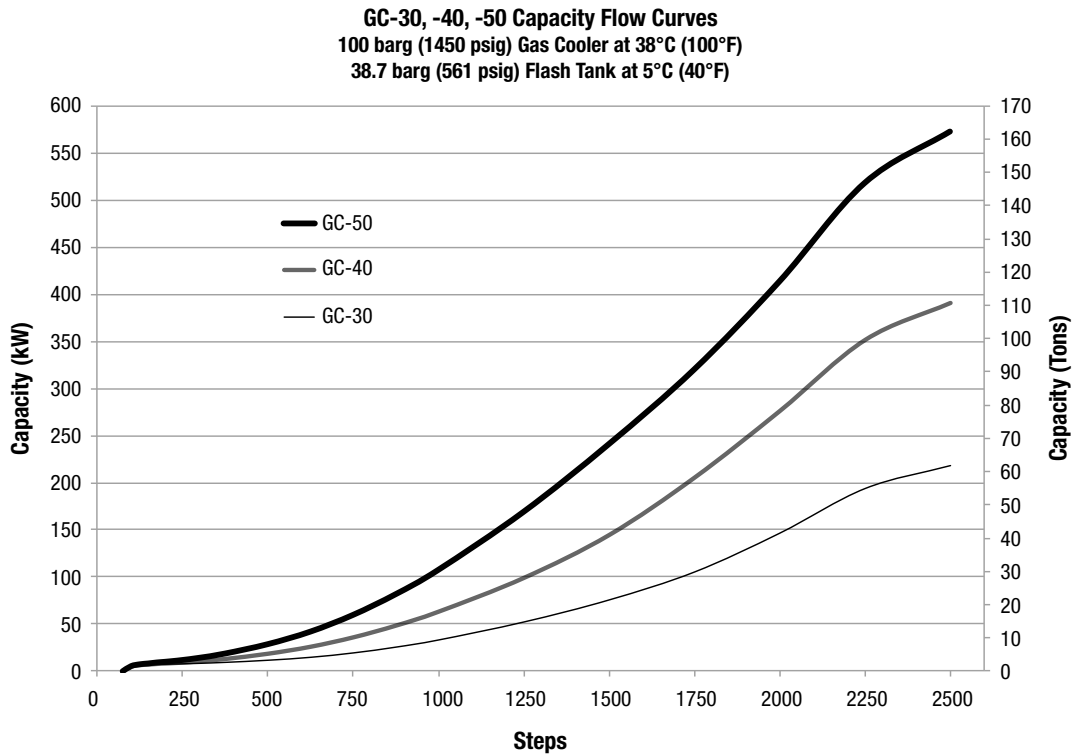
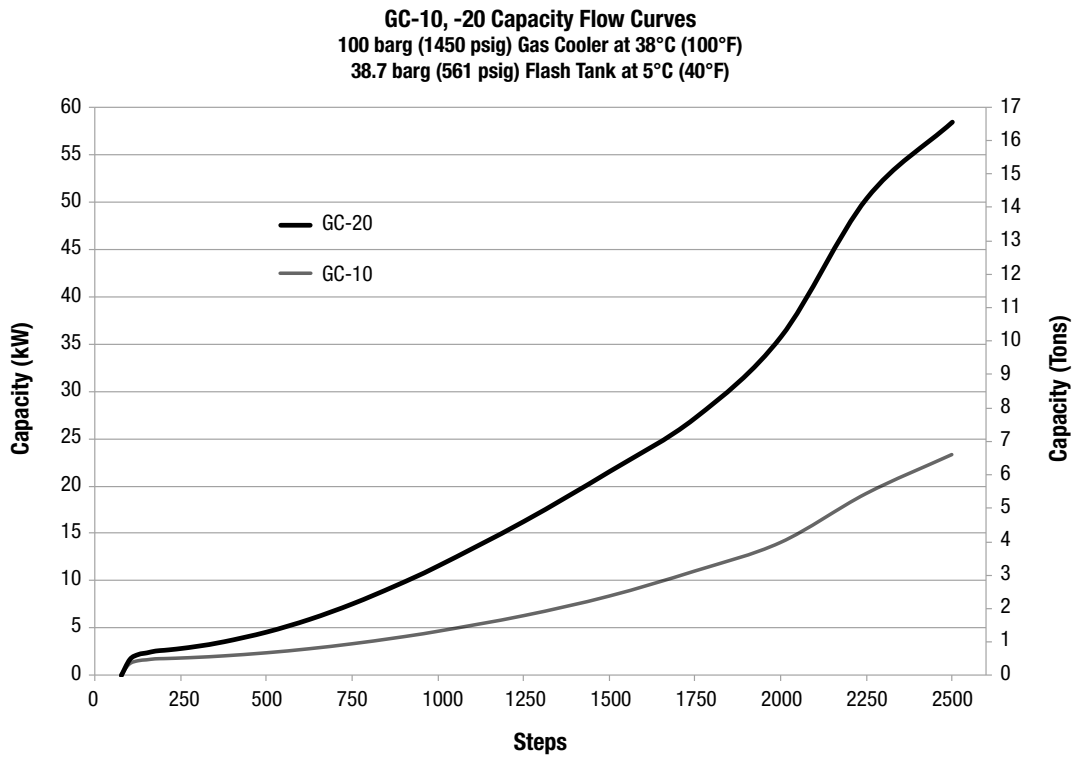

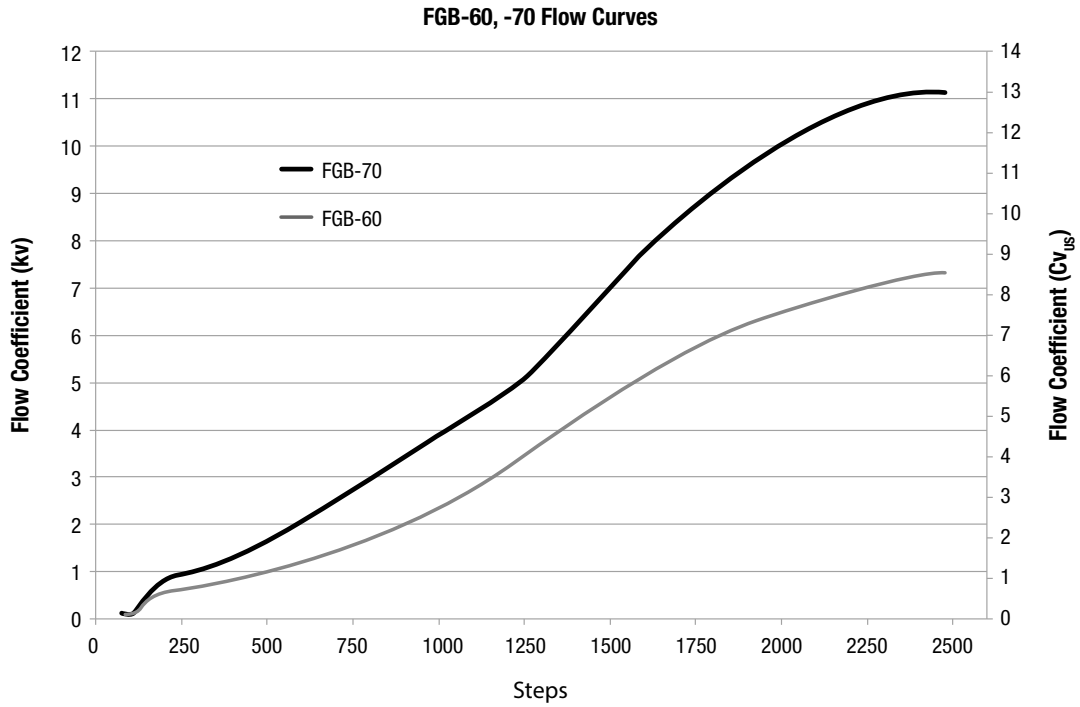

GAS COOLER VALVE CAPACITY*

GAS COOLER	44 bar(g) 10°C	50 bar(g) 15°C	100 bar(g) 38°C	638 psi(g) 51°F	725 psi(g) 59°F	1450 psi(g) 100°F
FLASH TANK	30 bar(g) -4°C	38.7 bar(g) 5°C	38.7 bar(g) 5°C	435 psi(g) 24°F	561 psi(g) 40°F	561 psi(g) 40°F

	kW			Tons		
GC-10	27.4	21.9	23.3	7.8	6.2	6.6
GC-20	62.1	49.6	58.4	17.7	14.1	16.6
GC-30	231	185	218	65.7	52.5	61.9
GC-40	444	355	390	126	101	111
GC-50	651	520	572	185	148	163

*Based upon standard fitting sizes.

FULL STROKE FLOW COEFFICIENTS

	Kv	Cv _{US}
GC-10	0.16	0.19
GC-20	0.48	0.55
GC-30	1.46	1.69
GC-40	2.80	3.24
GC-50	4.15	4.80
FGB-60	7.28	8.43
FGB-70	11.1	12.9

STANDARD FITTING CONFIGURATIONS

	1/2" (12.7mm)	3/4" (19.05mm)	1" (25.4mm)
GC-10	X		
GC-20	X		
GC-30		X	
GC-40			X
GC-50			X
FGB-60			X
FGB-70			X

Recommended Flash Gas Bypass Valve with GC-10 AS GAS COOLER VALVE

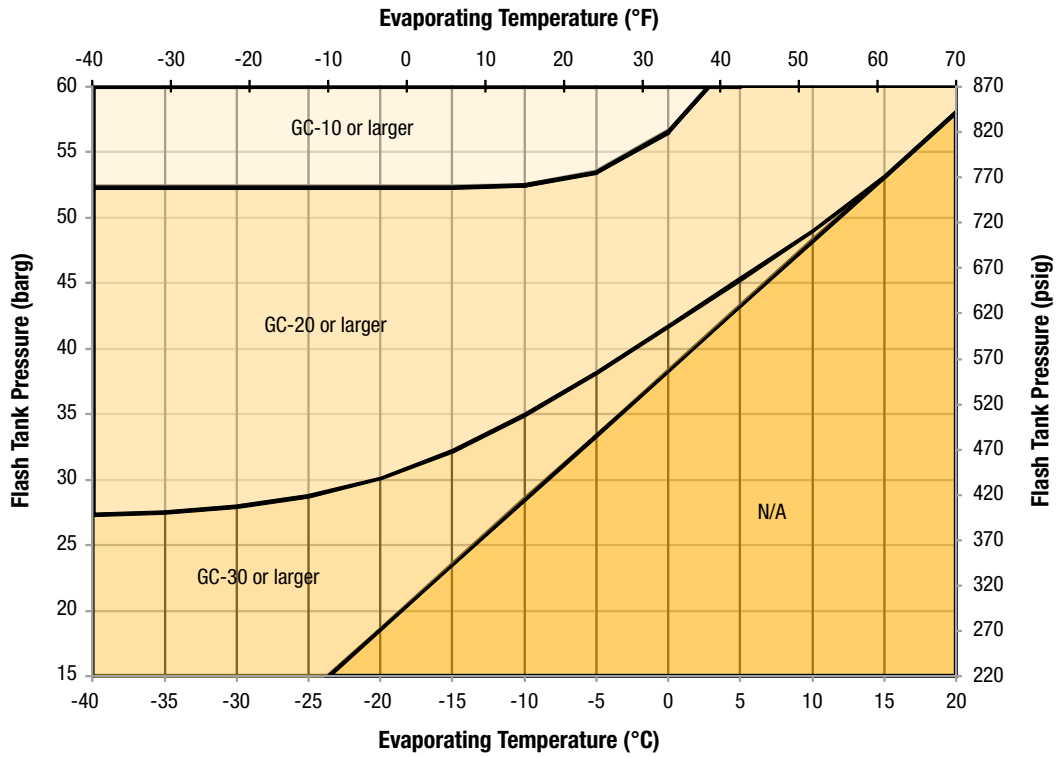

Recommended Flash Gas Bypass Valve with GC-20 AS GAS COOLER VALVE

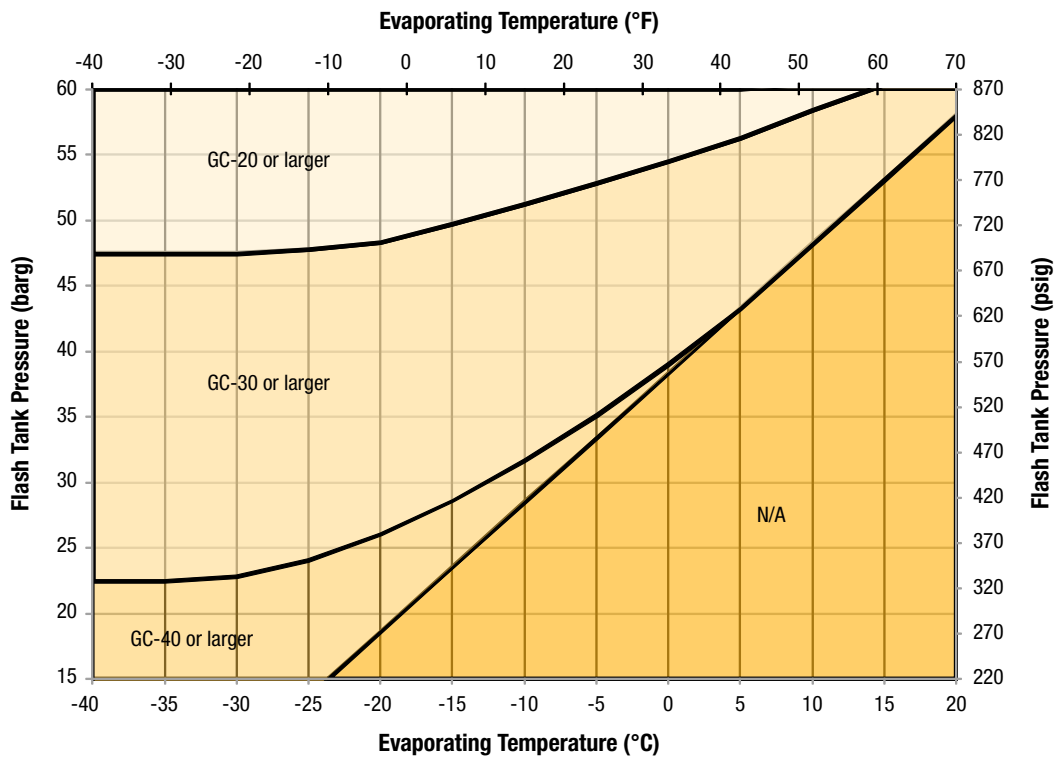

Recommended Flash Gas Bypass Valve with GC-30 AS GAS COOLER VALVE

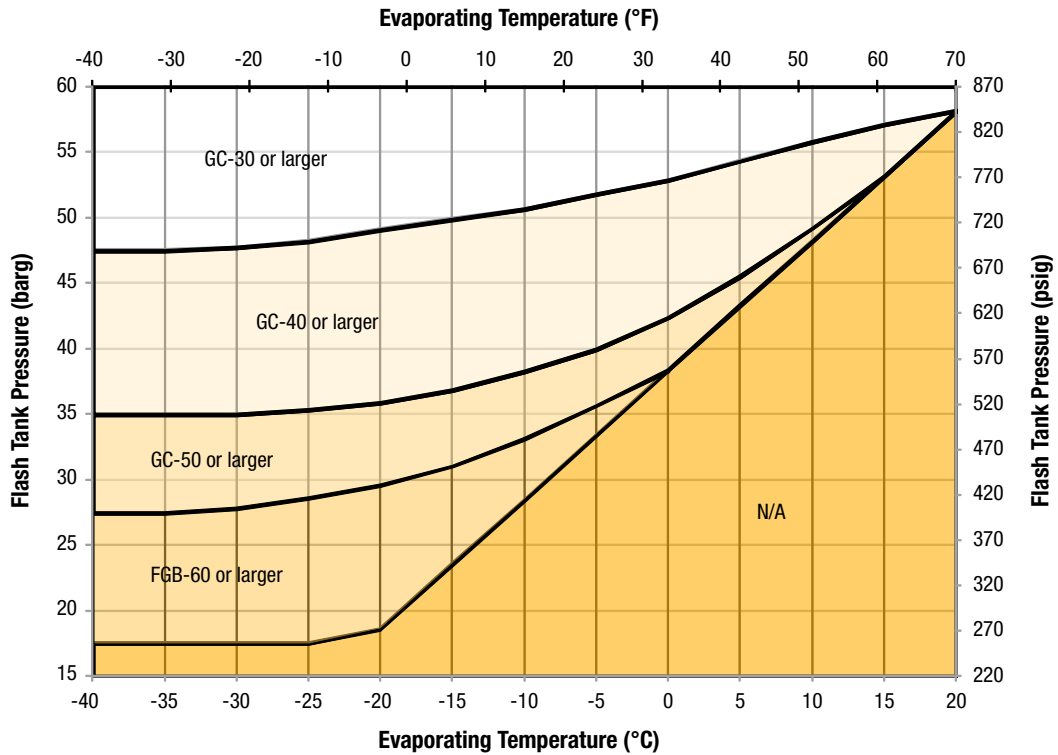

Recommended Flash Gas Bypass Valve with GC-40 AS GAS COOLER VALVE

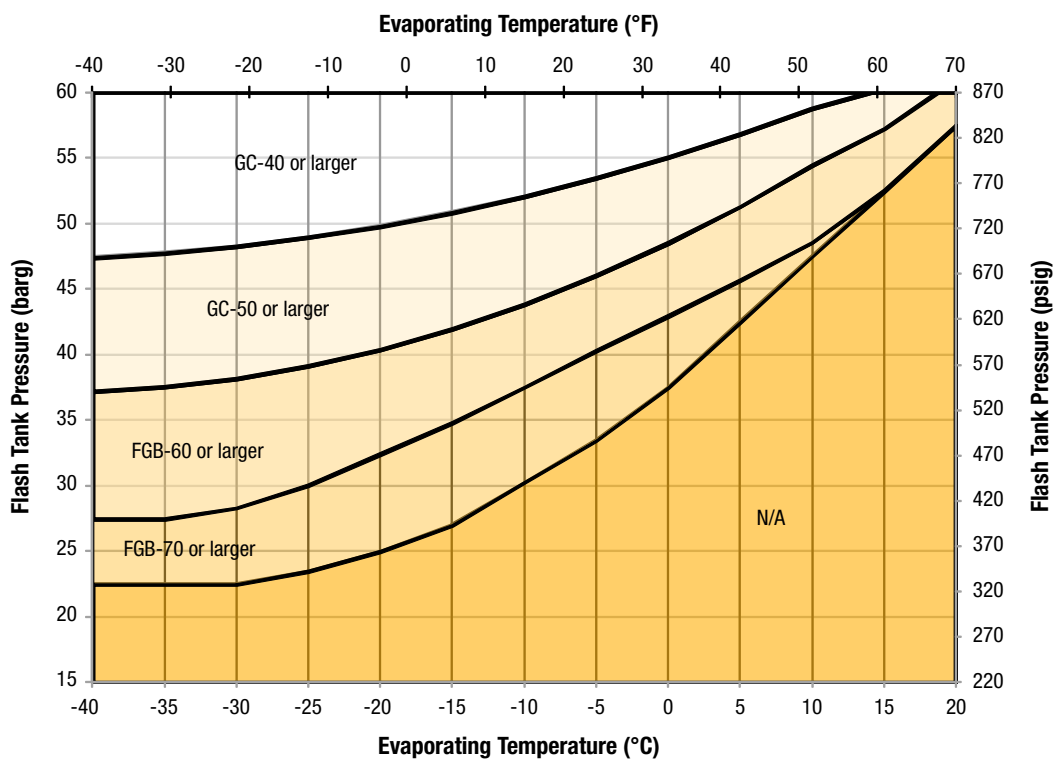

Recommended Flash Gas Bypass Valve with GC-50 AS GAS COOLER VALVE

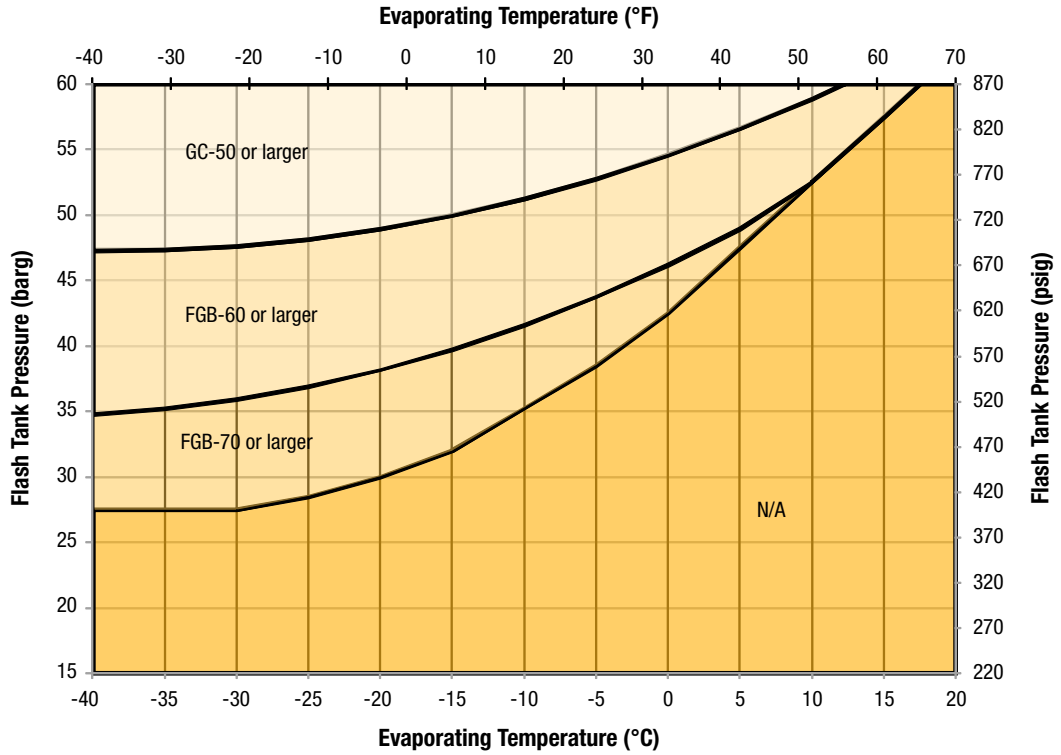

ACCESSORIES

Item	Description
PSD4BX3XXXVP	CO ₂ Valve Positioner
PSS4B	Backup Power Module



PSD4BX3XXXVP



PSS4B

VALVE CABLES (M12 CONNECTION WITH STRIPPED ENDS)

Item	Length
805194	10' (3m)
805195	20' (6m)
805343	30' (9m)
805344	40' (12m)



VALVE NOMENCLATURE

Valve Family - Capacity	Connection Size	Cable
GC	10	LESS CABLE
	20	
	30	
	40	
	50	
FGB	60	1"
	70	

AVAILABLE VALVE ITEM NUMBERS (LESS CABLE)

	1/2"	3/4"	1"
GC-10	953370	Upon Request	
GC-20	953371	Upon Request	
GC-30		953372	953373
GC-40			953374
GC-50			953375
FGB-60	Upon Request		953376
FGB-70			953377

TYPICAL WIRING DIAGRAM

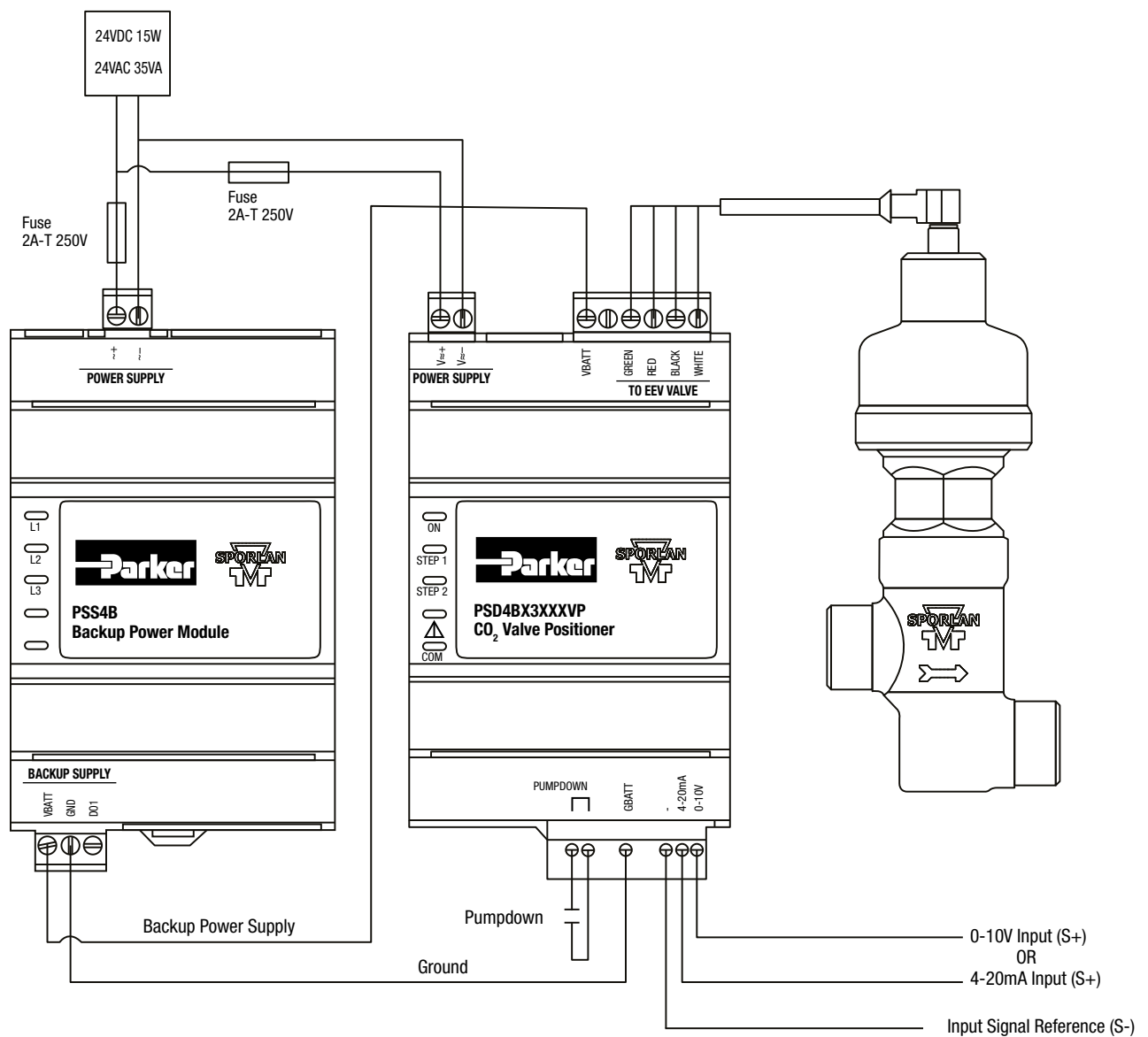

Parker Worldwide

**United Arab Emirates
Middle East**

Sarkis OHANNESSIAN
Tel +961 3334622
sohannessian@parker.com

**Germany and German
speaking part of Switzerland**

Francesco GALANTE
Tel +49 (0)175 5756 032
francesco.galante@parker.com

Spain and Portugal

Alberto PEÑA
Tel +34 609 153 154
alberto.pena@parker.com

**France, Belgium,
North Africa**

**French speaking part
of Switzerland**
Eliane EMERIT-BONNOT
Tel +33 (0)6 73 89 36 01
ebonnot@parker.com

**Italy, Greece, Malta, Cyprus
Italian speaking part
of Switzerland**

Andrea BRAGA
Tel +39 334 6944386
abraga@parker.com

Turkey

parker.turkey@parker.com

Ireland

Sean BRETT
Tel +353 (0) 1 868 9606
sbrett@parker.com

**Baltic Countries, UK,
Northern Europe, South Africa**

Kenny ADAMSON
Tel +44 (0)77853 71229
kadamson@parker.com

**Customer Service:
Parker Hannifin Ltd**

*Instrumentation Group
Refrigeration and
Air Conditioning Europe*
Manvers House
Office 21
Pioneer Close
Wath Upon Dearne
Rotherham S63 7JZ
United Kingdom
Tel +44 (0) 1709 774600
Fax +44 (0) 1709 774601
racecustomerservice@parker.com
www.parker.com/race



Your local authorized Parker distributor

